

SEDIVAC

COOLANT TANK MAINTENANCE SYSTEM



The **SediVac™** system provides an offline solution to a regular tank maintenance.

With the ability to filter out swarf and particulates down to 10µm at a flow rate up to 60l/min, the **SediVac™** prevents build-up of sediment within the machine tank and allows for easy regular offline filter bag replacement, reducing machine time interruptions.

The **SediVac™** system comes complete with an installation kit for efficient planning of machine tank flow, agitation and filtration.

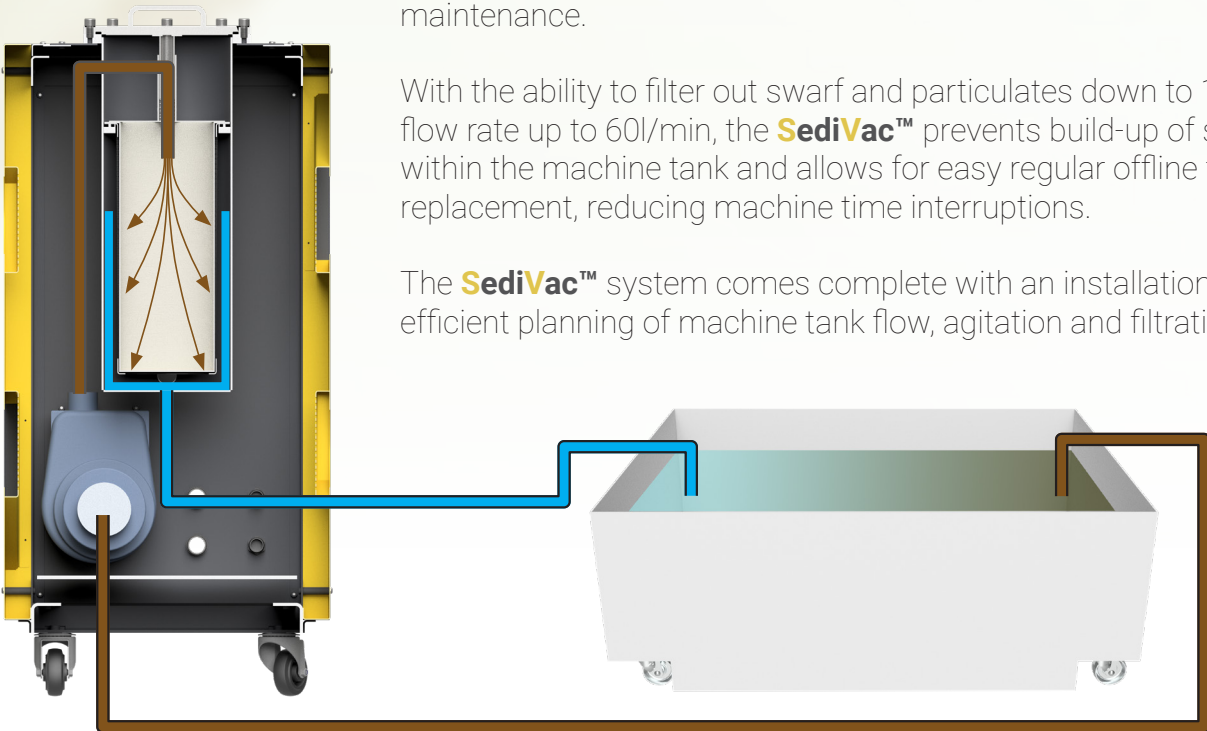

Sedivac Cutaway View

Machine Tank

DESIGNED AND MANUFACTURED BY

 **Pumps &
Equipment**

www.pumps-equip.co.uk



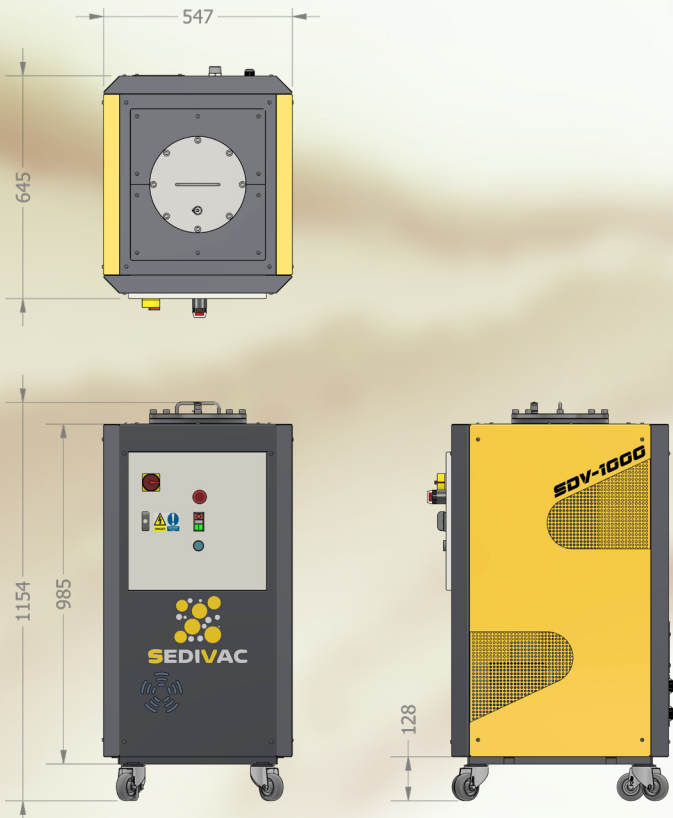

- Inlet - **Flooded Suction**
- Maximum Pressure - **2 Bar**
- Maximum Flow - **65 Litres**
- RPM - **2900**
- Voltage - **415V**
- Power - **10 Amps**
- Kilowatts - **1.2KW**
- Single Filter Bag - **10 micron**
- Integrated Control Panel -
- Filter Block Alarm -
- Castor Mounted -

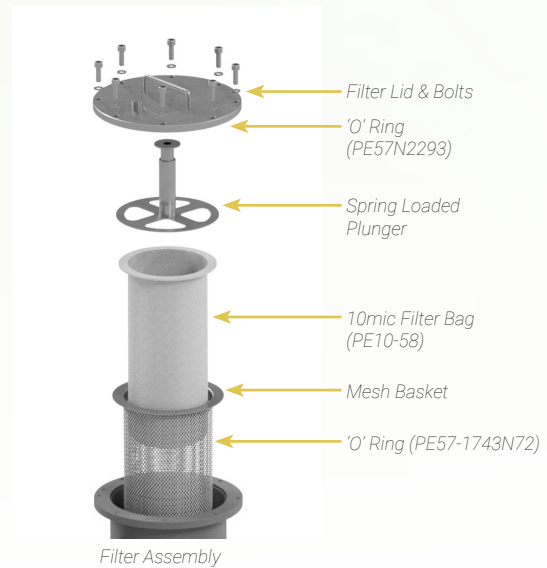

FOR FURTHER INFORMATION, PLEASE CONTACT:



Pumps and Equipment (Warwick) Ltd.
6 Collins Rd, Heathcote Industrial Estate,
Leamington Spa, CV34 6TF

T: 01926 451744
E: Sales@pumps-equip.co.uk

www.pumps-equip.co.uk